



(Reference Photo)

## EXTERNAL DIMENSIONS

Length(mm)	7492
Width(mm)	2492
Height(mm)(empty)	3471
Wheel base(mm)	3600+1400
Wheel track(mm)	Front 2045 Rear 1872
Min ground clearance(mm)	320
Approach angle(°)	25
Departure angle(°)	18
Front overhang(mm)	1492

## FEATURES

- Reliable 13L MAN engine with 540Hp and 2500 High Torque.
- 12 Speed ZF AMT gearbox.
- Luxury roomy Cab /Top Cooler/ ISRI Ventilated heated seat/ 20L Refrigerator/LED Light /ZF Retarder as standard.
- Differential locks and cross locks for when the going gets tough.
- Alloy rim/air tank/fuel tank/Air suspension to reduce tare weight.
- Bosch steering pump /Continental Color display/Knorr brake control/Voss connector/JOST fifth wheel.
- Fully complied with Australia Design Rules.

## WEIGHTS

Max load of two axles (kg)	Front	7000
GCM (kg)	Rear	18000 75000

## CAPABILITY

Max speed(km/h)	100
Min turning diameter (m)	17.8
Max climb gradient (%)	≥30
Fuel tank (L)	600L

## CABIN

Model	G7S-P
Sits	2
Turning radius (mm)	2897

## ENGINE

Model	MC13.54-61
Displacement (L)	12.419
Power rating kW/(r/min)	400/1900
Max torque Nm/(r/min)	2500/1050-1350

## CLUTCH

Model	CH430-25 diaphragm
Operation Mode	Electrically controlled operating with air

## TRANSMISSION

Model	ZF 121X2621 TD
Forward gear ratio	16.688, 12.924, 9.926, 7.688, 5.895, 4.565, 3.655, 2.831, 2.174, 1.684, 1.291, 1
Reverse gear ratio	15.537, 12.033, 3.403, 2.636

## FRAME

Model	Channel frame
Main beam cross-section (mm)	300×80×8
Width of frame Assembly(mm)	Front 940 Rear 850

## DRIVING AXLE

Redactor ratio	Ratio	3.08
Differential lock	Optio	2.85, 3.08, 3.7, 4.11 Diff lock+ cross lock

## FRONT AXLE

Model	VPD71DS
-------	---------

## SUSPENSION

Front	Model	Non-independent
	Number	3 leaf parabolic
Rear	Model	Non-independent
	Number	8 air bag

## STEERING GEAR

Model	Bosch 8098
Ratio	22.2-26.2
Max pressure of pump (kPa)	18300
Steering way	Recirculating ball

## BRAKING SYSTEM

Working pressure (kPa)	1000
Drive braking type	Dual circuit
Brake power adjust type	EBS ESC AEBS
Parking brake type	Spring stored energy air cut brake
Assistant brake typ	FVR

## ELECTRICS

Circuit type	double, control positive pole
Voltage (V)	24
Generator power (kW)	2.0
Accumulator voltage / capacity(V/Ah)	2x12/240

## EXTRAS

Trailer brakes ABS to rear	Included
Sun visor, side skirts	Included
Retarder	ZF Retarder

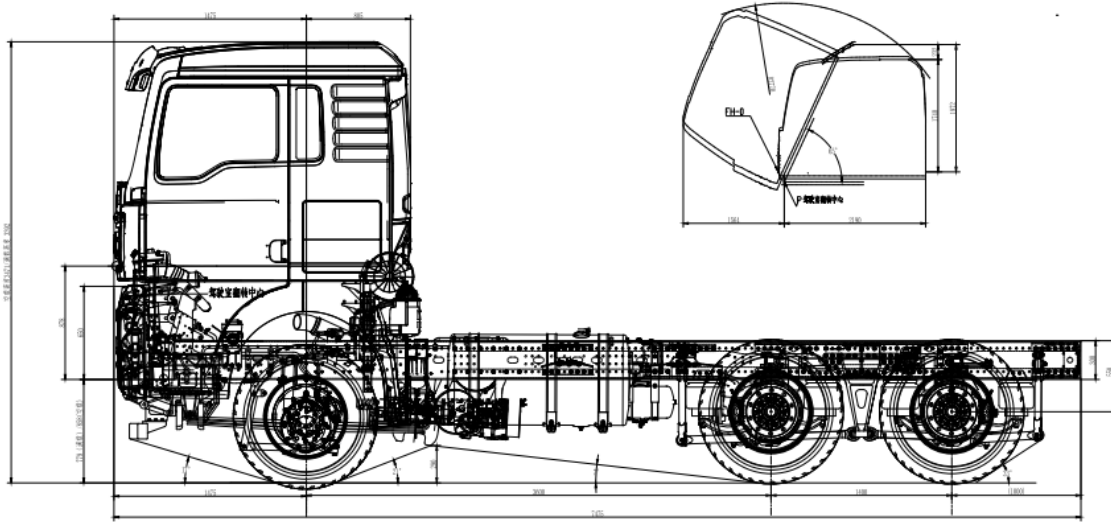

图例: G7S  
 图例: 取料斗  
 图例: 取料斗(带取料斗) 4000kg 取料斗  
 图例: 取料斗(带取料斗) 4000kg 取料斗  
 图例: 取料斗(带取料斗) 4000kg 取料斗  
 图例: 取料斗(带取料斗) 4000kg 取料斗  
 图例: 取料斗(带取料斗) 4000kg 取料斗  
 图例: 取料斗(带取料斗) 4000kg 取料斗

本图仅供参考, 不作为法律依据。如有变更, 恕不另行通知。

